

Masking Station

Model 45146

ASSEMBLY AND OPERATING INSTRUCTIONS

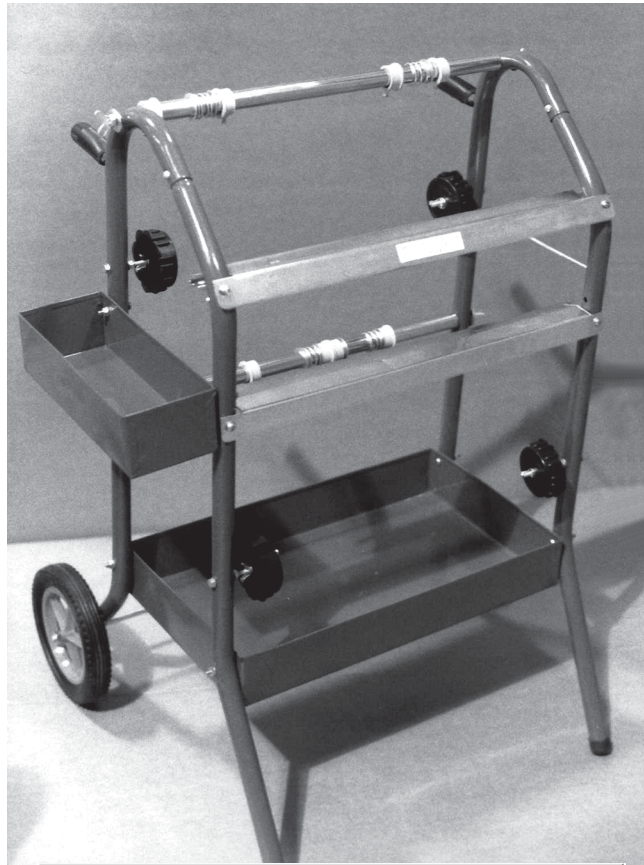

3491 Mission Oaks Blvd., Camarillo, CA 93011

Visit our Web site at <http://www.harborfreight.com>

**TO PREVENT SERIOUS INJURY,
READ AND UNDERSTAND ALL WARNINGS
AND INSTRUCTIONS BEFORE USE.**

Copyright© 2001 by Harbor Freight Tools®. All rights reserved. No portion of this manual or any artwork contained herein may be reproduced in any shape or form without the express written consent of Harbor Freight Tools.

For technical questions and replacement parts, please call 1-800-444-3353.

MODEL # 45146 MASKING STATION SPECIFICATIONS

Construction:	Formed Stamped Sheet Steel w/ Welded Tubular Steel
Axle Holder:	20-1/8" L x 7/8" Thick
Cart:	29"L x 25"W x 36"
Tubular:	1" Thick
Wheel:	8-1/4" Dia. x 1"W (Tire)
Wheel Support:	Axle w/Two Hex Center Lock Cap
Blade:	22-1/16"L x 2-7/8"W

PRODUCT FEATURES

1. This cart provides a convenient, movable storage and work unit for masking paper and tape.
2. Hold two rolls of paper and 4 rolls of tape for convenient dispensing of masking materials.
3. Strong steel construction promises long service life.
4. Sturdy plastic wheels aid mobility, built-in trays and towel rack offer convenient features.
5. Large tray stores extra rolls of tape, cleaning towels, cleaner and other materials.
6. Small tray conveniently holds trimming knives and other tools.
7. Towel rack holds and stores wiping towels.

USING THIS PRODUCT

This masking station will hold two rolls of masking paper, with two rolls of tape for each roll. By aligning the tape with the edge of the paper, and threading the materials through each cutter blade, it is possible to dispense and cut off a preassembled section of masking paper with tape along two edges. This makes it very convenient to mask objects such as vehicles and equipment prior to painting or other treatment.

SAVE THIS MANUAL

You will need this manual for the safety warnings and cautions, assembly instructions, operating procedures, maintenance procedures, trouble shooting, parts list, and diagram. Keep your invoice with this manual. Write the invoice number on the inside of the front cover. Keep both this manual and your invoice in a safe, dry place for future reference.

WARNING

***Do not overload this masking station.
Do not unbalance the weight load of materials stored on this station.
Use caution in working with the cutter blades, they are very sharp.***

NOTICE

The Warnings, Cautions, and Instructions discussed in this instruction manual cannot cover all possible conditions and situations that may occur. It must be understood by the operator that common sense and caution are factors which cannot be built into this product, but must be supplied by the operator.

SAFETY WARNING & CAUTIONS

READ ALL INSTRUCTIONS BEFORE USING THIS TOOL!

1. **KEEP WORK AREA CLEAN.** Cluttered areas invite injuries. Do not use tools in damp, wet, or poorly lit locations. Don't expose to rain. Keep work area well lit.
2. **KEEP CHILDREN AWAY.** Children must never be allowed in the work area. Do not let them handle machines, tools, or equipment.
3. **STORE IDLE EQUIPMENT.** When not in use, tools must be locked up in a dry location to inhibit rust. Always lock up tools and keep out of reach of children.
4. **DO NOT FORCE THE TOOL.** It will do the job better and more safely at the rate for which it was intended. Do not use inappropriate attachments in an attempt to exceed the tool's capacities.
5. **USE THE RIGHT TOOL FOR THE JOB.** Do not use a tool for a purpose for which it was not intended.
6. **DRESS PROPERLY.** Do not wear loose clothing or jewelry, as they can be caught in moving parts. Nonskid footwear is recommended. Wear restrictive hair covering to contain long hair. Always wear appropriate work clothing.
7. **DO NOT OVERREACH.** Keep proper footing and balance at all times. Do not reach over or across running machines.
8. **MAINTAIN TOOLS WITH CARE.** Keep tools maintained and clean for better and safer performance.

SPECIAL WARNINGS WHEN USING THIS MASKING STATION

1. Wear appropriate work gloves and safety shoes when handling this cart and heavy items.
2. Be careful when handling or storing sharp tools, knives, cleaners and solvents. Each of these present their own hazards. Check with the manufacturer's warnings and instructions when using these tools and materials.
3. Keep the weight load evenly balanced on the masking station. Excessively heavy loads on the top or one side of the station may create instability, with danger of the cart toppling over and possibly injuring a person or causing property damage.
4. Do not use solvents or flammable materials to clean this station. A mild detergent in water will be sufficient. Solvents may damage the bins and the paint; and possibly create fire hazard.
5. Be careful to avoid cutting yourself on the cutter blades, or on the edges of the paper or tape you will be working with.

ASSEMBLY

You will need an assortment of small hand tools to complete assembly of this Masking Station.

1. Find a suitable assembly area, and arrange the parts for the masking station where they can be easily worked with.
2. Insert one Front Frame (G) into one Rear Frame (E) as shown in *Figure 1*. Insert the swagged end of the Front Frame into the curved portion of the Rear Frame near the handle. Be sure the lock buttons on the front frames fit into the holes in the rear frames.
3. Assemble the Large Bottom Tray (C) between the two frame assemblies. Attach using two screws, four washers and two nuts per side.
4. Insert the Axle (A) through the bottom holes in the Rear Frames, as shown in *Figure 2*. Snap on one C-clip per side into the groove just outside each rear frame.
5. Assemble the wheels. Slide one Wheel (B) and one Axle Nut per side as in *Figure 3*. Tighten the nuts.
6. Remove the Wing Bolts and Washers from each Spring Bar Assembly. Slide 2 sets of Paper Roll Components onto each Spring Bar, as shown in the *detail photo on page 7*.
7. Place a Spring Bar Assembly between the uppermost holes in the Frame Assemblies. Insert the Wing Bolts and Washers through the holes in the Frame Assemblies and into the Spring Bar assembly as shown in the *detail photo below*.
8. Repeat steps 6 and 7, placing the second Spring Bar Assembly between the large holes in the Rear Frame above the Large Bottom Tray. See *Figure 4*.
9. Insert one long bolt and large washer through the rear frame (as viewed from behind the wheels), using the hole located behind the hand grip. Place a large washer and nut onto the threads and tighten against the rear

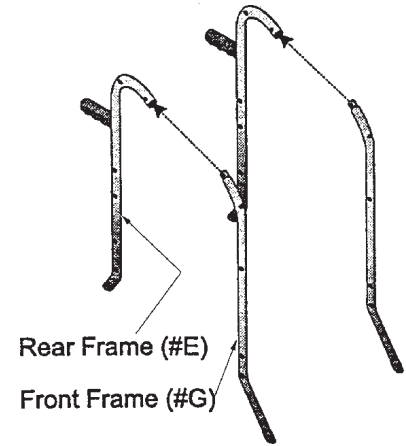

Figure 1. Frame Assembly

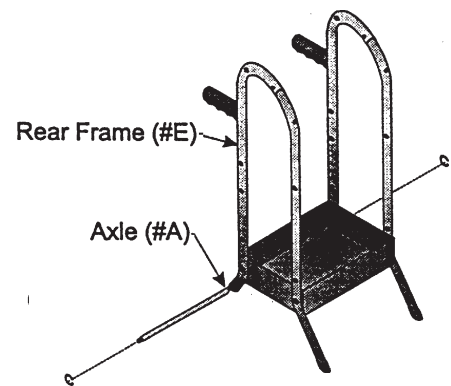
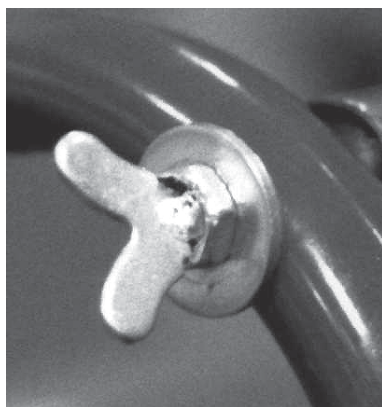

Figure 2. Large Tray and Axle Assembly



Wing Nut on Spring Bar Detail

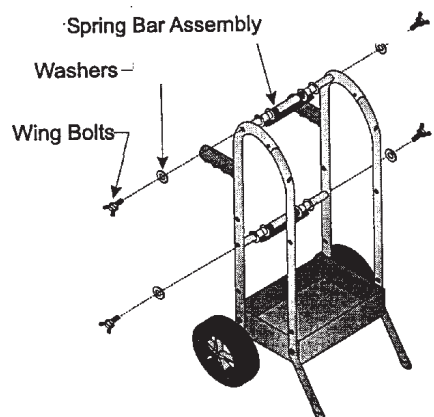

Figure 4. Spring Bar Installation

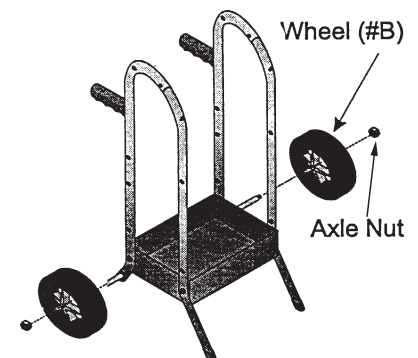

Figure 3. Wheel Installation

- frame as shown in *Figure 5*.
10. Repeat step 9 using the hole below the hand grip in the right rear frame.
 11. Repeat step 9 using the holes located on the front frames just above the large bottom tray.
 12. Select one of the bolts you have just installed, and thread a wing nut and washer halfway onto the bolt. Thread the wing nut on so that the flat side of the wing nut faces to the inside of the frame assembly. *See detail photo.*
 13. Insert the metal bushings into the center of the tape roll holders.
 14. Place one tape roll holder with the metal bushing installed onto one of the bolts. Face the tape roll holder so the flanges are nearest to the frame. Thread on a washer and wing nut to the bolt as shown in *the detail photo*. Tighten against the tape roll holder.
 15. Repeat steps 12- 14 to install the remaining three tape roll holders.
 16. Install both cutting blades (H) onto the front frames as shown in *Figure 6*. Mount upper blade with the cutting edge down, and lower blade with cutting edge up. Assemble using two screws, four washers, and two nuts per paper cutting blade. Carefully fit a long spring (L) on the bottom of the front edge of the lip of the paper cutting blade (H). Secure the hooks on each end of the spring in the holes on the paper cutting blade. Repeat with the other blade.
 17. Attach the small side tray to the right side of the assembly using two bolts, nuts and washers.
 18. Attach the towel holder to the left side of the assembly. Insert the ends of the rack into the holes on the side of the assembly, rotating them upward to “hook” the rack into the frame.

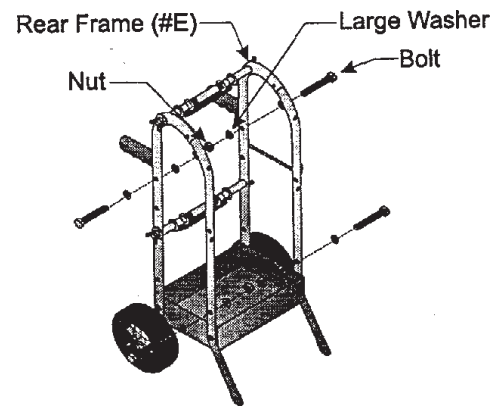
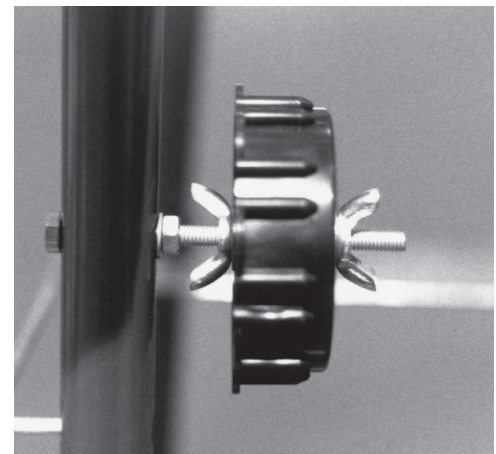

Figure 5. Tape Roll Holder Bolt Assembly



Tape Roll Holder Detail Photo

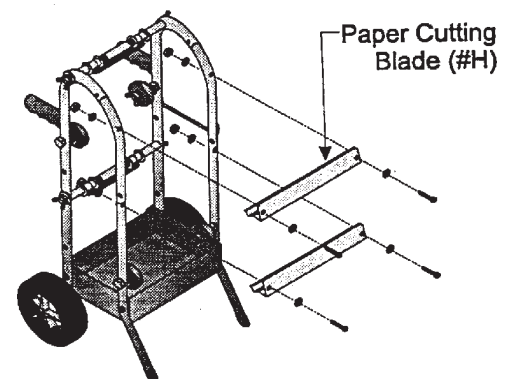
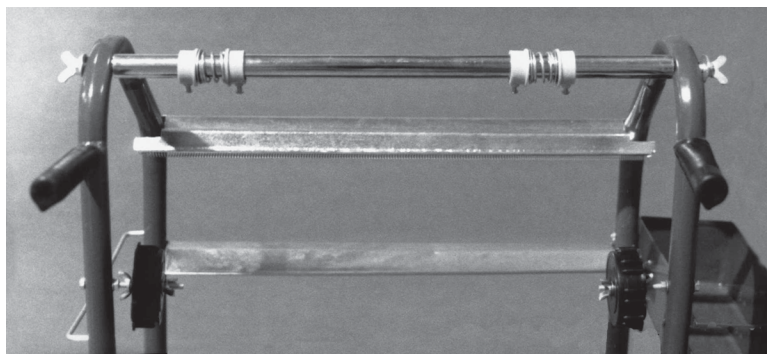
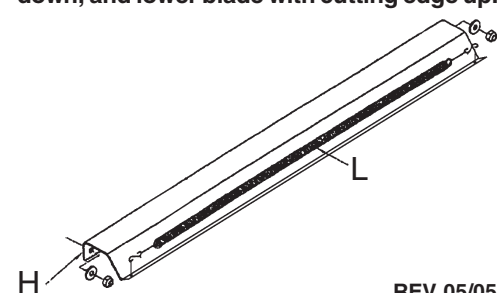

Figure 6. Cutting Blade Installation. Mount upper blade with the cutting edge down, and lower blade with cutting edge up.



Rear View of Complete Upper Assembly Back View.



OPERATION

When properly set up, this masking station will hold up to 2 rolls of masking paper and up to 4 rolls of masking tape. These materials may be arranged so the masking station will dispense the paper with the tape pre-applied to the edges of the paper. This paper / tape assembly may be pulled out and cut from the masking station for easy and rapid use in masking workpieces for painting or other treatment.

Installing the tape rolls

1. Select any of the upper or lower pairs of tape roll holders for installation of a new tape roll.
2. Check to be sure that both wing nuts are tight against the tape roll holder.
3. Press the tape roll onto the holder.
4. Check the alignment of the tape with the paper roll.
5. If you need to adjust the position of the tape roll, you may adjust the wing nuts. First, move the outer wing nuts back out of the way. Then, move the inner wing nuts in or out until the tape is properly aligned with the paper roll. Retighten both wing nuts to fix the tape roll into position.

Note: If you are using narrower paper rolls, you may replace the long bolts with threaded rods of the same diameter to allow you to position the tape roll holders even closer together.

You can also adjust the position of the paper roll to better align with the tape rolls.

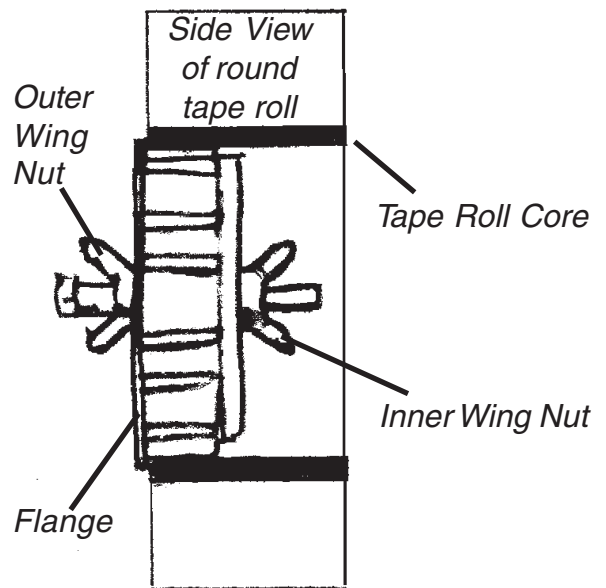

The tape roll is pressed onto the holder. The holder position may be adjusted by moving both the inner and outer wing nuts.

Note: Review the paper path illustration in figure 7 before installing paper or tape.

6. Position the paper roll so that the paper unwraps from the top of the roll, toward the cutting blades of the masking station.
7. Position the tape rolls so that the sticky side of the tape will be adhered to the paper as it passes under the springs on the cutting blades.

Installing the paper rolls.

1. Each spring bar assembly is designed to hold a full roll of paper. Select either spring bar for installation of a new roll of paper.
2. Remove the wing nuts on both sides of the spring bar assembly, and place the assembly on your workbench for installation of the paper.
3. Loosen the screws in one or both of the retainer sets, and slide them off the spring bar.
4. Slide a paper roll onto the spring bar, abutting the remaining retainer set. The paper roll should be positioned so that when the spring bar assembly is reinstalled onto the masking station the paper will pull off the top of the roll toward the cutting blades.
5. Slide the retainers back onto the spring bar assembly, and replace the assembly back onto the masking station.
6. Retighten the screws in the retainers to hold the paper roll firmly in position.
7. If desired, you may align the paper with the edges of the tape rolls. To do so, loosen the screws in both sets of retainers, and slide them with the paper roll along the spring bar until the edges of the paper roll is aligned with the center of the tape rolls. Tighten the screws in the paper retainers to secure this position on the spring bar.

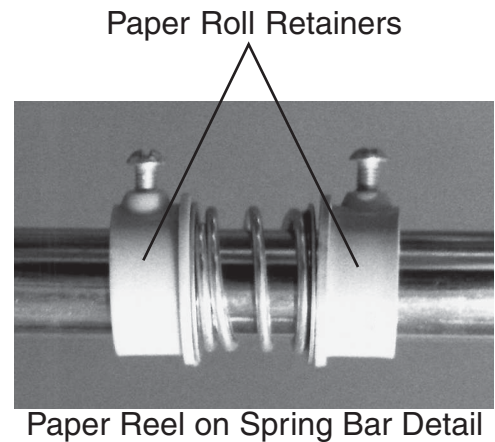

Threading the Paper and Tape through the Cutting Blades.

NOTE: The upper tape rolls and upper paper roll will feed through the upper cutting blade. The lower paper roll and lower tape rolls will thread through the lower cutting blade.

1. Pull out the paper from the roll, and pass it behind the cutting blade, under the spring, over the cutting edge, and out to the front of the masking station.
2. Repeat step 1 with each roll of tape. If you have aligned the tape with the edge of the paper, attach the tape to the paper, and pull the paper / tape combination through the spring and out to the front of the masking station. *Note that the spring holds the leading edge of the materials onto the cutting bar, and also rubs the tape onto the paper just before cutting.*

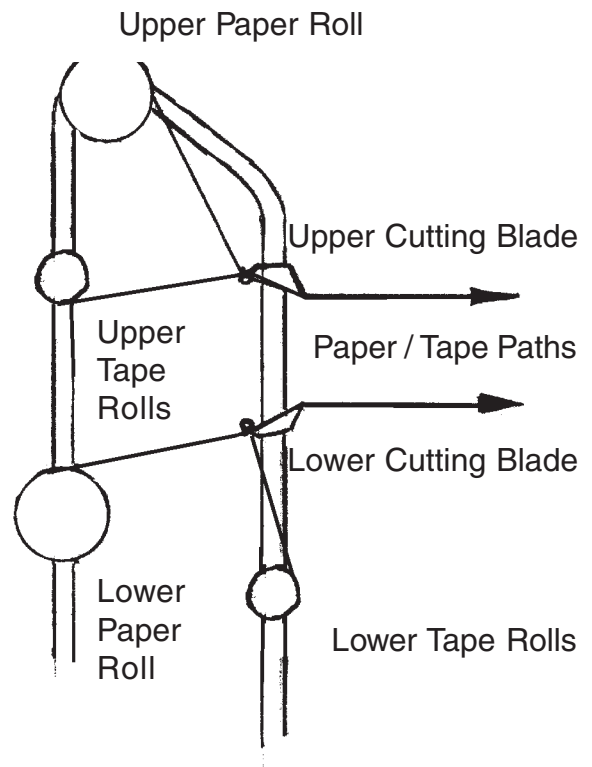
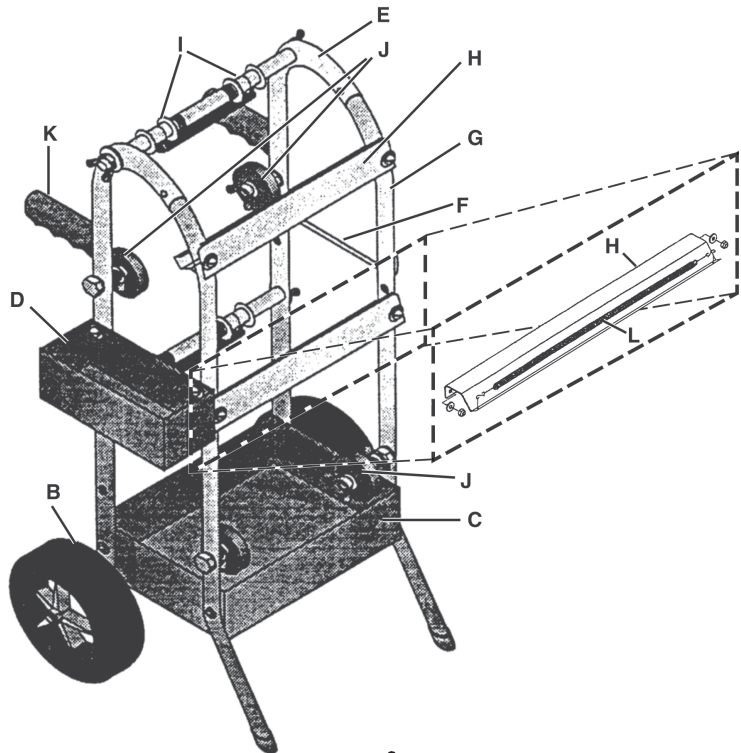

Figure 7. Paper and Tape Path

MASKING STATION PART & HARDWARE DIAGRAMS

Parts

Part	Description	Q'ty
A	Axle	1
B	Wheel	2
C	Large Tray Bottom	1
D	Small Side Tray	1
E	Rear Frame	2
F	Towel Rack	1
G	Front Frame	2
H	Cutting Blades	2
I	Paper Reel	4
J	Tape Roll Holder	4
K	Hand Grip	2
L	Long Spring	2



Hardware

Number	Description	Q'ty
1	Cap Nut M10	2
2	C-clip	2
3	Washer Ø6	28
4	Nut M6	18
5	Wing Nut M6	4
6	Wing Bolt M10x40	4
7	Screw M5x12	8
8	Large Washer	8
9	Bolt M6x75	4
10	Bolt M6x40	10
11	Rubber Foot	2

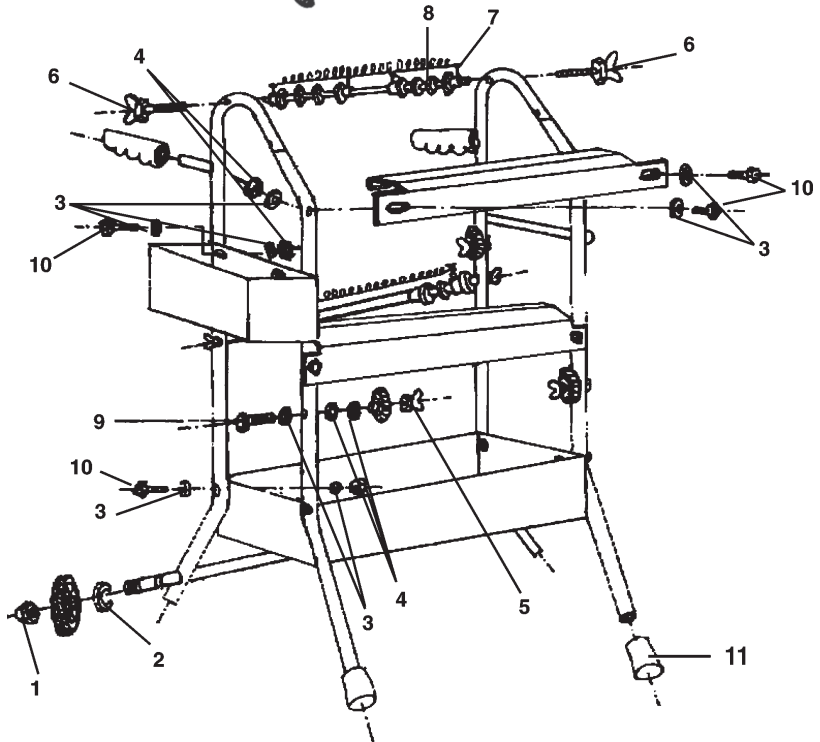

PLEASE READ THE FOLLOWING CAREFULLY

THE MANUFACTURER AND/OR DISTRIBUTOR HAS PROVIDED THE PARTS DIAGRAM IN THIS MANUAL AS A REFERENCE TOOL ONLY. NEITHER THE MANUFACTURER NOR DISTRIBUTOR MAKES ANY REPRESENTATION OR WARRANTY OF ANY KIND TO THE BUYER THAT HE OR SHE IS QUALIFIED TO MAKE ANY REPAIRS TO THE PRODUCT OR THAT HE OR SHE IS QUALIFIED TO REPLACE ANY PARTS OF THE PRODUCT. IN FACT, THE MANUFACTURER AND/OR DISTRIBUTOR EXPRESSLY STATES THAT ALL REPAIRS AND PARTS REPLACEMENTS SHOULD BE UNDERTAKEN BY CERTIFIED AND LICENSED TECHNICIANS AND NOT BY THE BUYER. THE BUYER ASSUMES ALL RISK AND LIABILITY ARISING OUT OF HIS OR HER REPAIRS TO THE ORIGINAL PRODUCT OR REPLACEMENT PARTS THERETO, OR ARISING OUT OF HIS OR HER INSTALLATION OF REPLACEMENT PARTS THERETO.